



EIMCO ELECON

# Most Economical Hydrostatic Articulated Wheel Loader AL 120

Swift.... Fuel Saver.... Rugged....



- Bucket Capacity 1.2 / 1.4 / 1.6 m<sup>3</sup>
- 4 x 4 Wheel Drive
- Easy handling with single lever operation
- Excellent Maneuverability
- Z Bar Linkage for High Breakout Force
- Hydrostatic Drive with Automatic Control
- Spacious Operators Cab with Excellent Visibility
- Reliable for various attachments

# SPECIFICATION

## ENGINE

Type : Water Cooled Diesel Engine  
 4 Cylinders, 4-Stroke,  
 Make & Model : Kirloskar 4R1040TC, BS-III  
 Net Power : 76HP @ 2200 rpm  
 Max. Torque : 300 Nm @ 1500 rpm

## HYDROSTATIC DRIVE

- Higher Fuel Efficiency.
- Elimination of Clutch & Transmission related Mechanical losses.
- High Tractive effort.
- Self locking Braking system.
- High Torque available for startup.
- Easy Maintenance.

## HYDRAULIC SYSTEM

- Three-way control valve with primary and secondary safeguard.
  - Servo-assisted joystick controls with float position for lifting cylinder.
  - Hydrostatic inching brake, acting on all 4 wheels.
- Operating pressure .....230 bar  
 Flow @ 2200 rpm ..... 90 L/min

## STEERING

Hydrostatic steering,  
 Maximum steering angle +/- 40°  
 Turning radius (Over rear end) 3780 mm

## OPTIONAL

An extensive range of attachments including Pallet Forks, Jibs crane, Quick hitch mounting, Silage forks, 6-in-1 Clam Shovel Bucket, Sweeper.

## PERFORMANCE DATA

Bucket position : Crowd angle..... 45°  
 Dumping angle, top..... 45°  
 Dump angle max..... 125°  
 Breakout force : ..... 5098 kg  
 Payload : ..... 2400 kg  
 Transport position 300 mm above ground.

## SERVICE CAPACITY

Fuel tank : 100 ltr  
 Engine oil : 9.5 ltr  
 Engine Coolant : 12 ltr  
 Hydraulic System : 80 ltr  
 Rear Axle : 7.2 ltr  
 Front Axle : 6.2 ltr

## AXLES

- Multi Disc Symmetric brakes.
- Self Adjustment Braking system (Constant Stroke of Pedal).
- High Energy dissipation (Good Oil Circulation).
- Wear Free Discs.
- SAHR brakes integrated in rear axle housing.



Particular	Standard Bucket	6-in-1 Clam Shovel Bucket
A	5900	5860
B	45°	45°
C	1515	1515
D	-	530
E	830	815
F	2700	2700
G	3300	3300
H	-	3620
I	4520	4385
J	720	700
K	70	100
L	350	350
Front View		
M	2000	2100
N	1925	1925
O	1525	1525
P	2720	2720

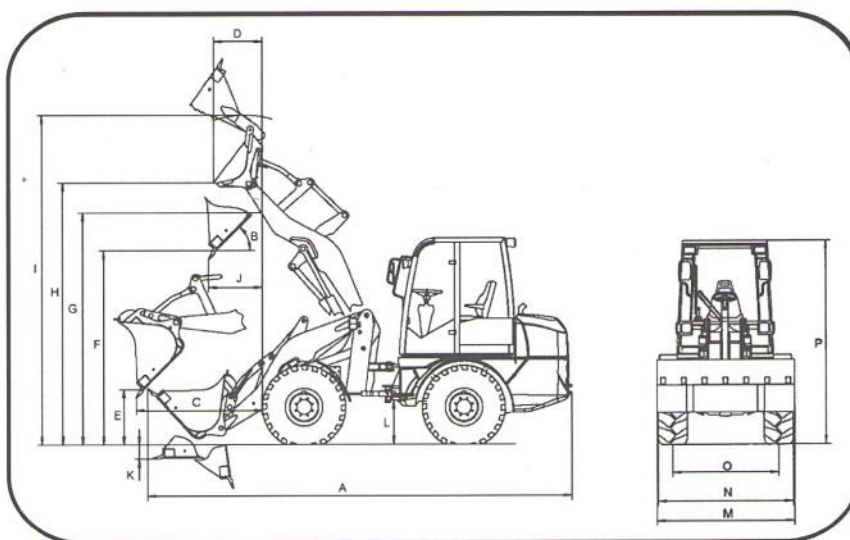

All dimensions are in mm, and may vary within +/- 5%  
 Manufacturers reserve the right to amend/modify the specifications and/or design at any time without notice.

**For further details, please contact**



**EIMCO ELECON (INDIA) LTD.**

ANAND SOJITRA ROAD, VALLABH VIDYANAGAR 388 120. GUJARAT, INDIA.

Tel. : (02692) 227850, 227859, Fax : (02692) 236506, E-mail : mktg.ces@eimcoelecon.in, Website : www.eimcoelecon.in

**BRANCH OFFICES**

Ahmedabad, Bangalore, Bilaspur, Chennai, Hyderabad, Indore, Kolkata, Madurai, Mumbai, Nagpur, New Delhi, Pune, Raipur, Vadodara

**INTERNATIONAL NETWORK**

Dubai, Singapore